

ML-SM-150C-D-1

includes
150 Watt CMH Projector, and Gimbal Mounting

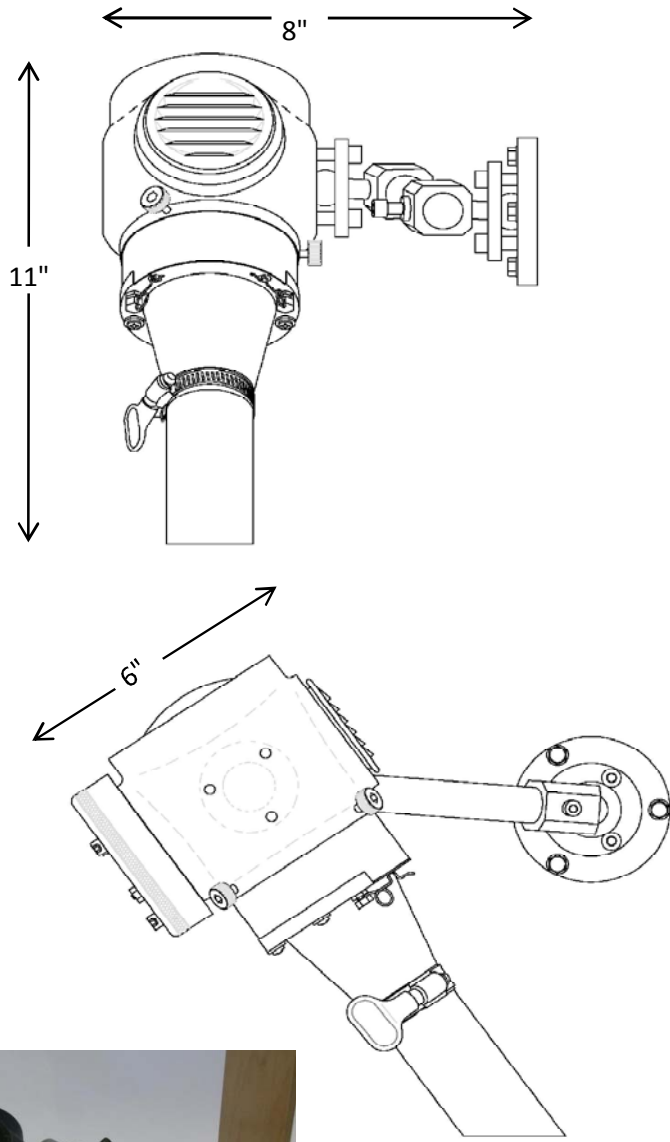

Projector Specifications

Description	Merlin Light® Precision optical framing projector
Catalog #	ML-SM-150C-D-1
Application	Surface mount for all models of Merlin Light where an exposed projector is desired.
Lamp & Base	150 Watt Ceramic Metal Halide Lamp L3-R
Remote Ballast	150 Watt Ceramic Metal Halide Lamp and 150W, 120/277 VAC electronic ballast, dimmable to 50%. Time delay on hot restart.
See wiring detail sheet	0-10V wiring and interface required for dimming
Projector P1	Cast aluminum body with black anodize finish. Projector will be supplied and installed by a GlennCo Inc. or factory certified technician. Installer will make final installation and confinement on art object being illuminated.
Mounting M1	Gimbal Mount
Lens	Objective lens selected by installation technician.



652 W. Confluence Ave Salt Lake City, UT 84123
801-312-0150
www.merlinlights.com
*Copyright Protected, GlennCo INC. 2012

